

# SPECTRE

4X8 / 5x10 / CUSTOM SIZES

## Machine Specifications

Machine Voltage	Working Area	Vacuum Table	Machine Structure
220V Three Phase 3 wire 60HZ 50Amp	X Y Axis: 4' x 8' 5' x 10' Z Axis: 11.8"	Bakelite Vacuum Table Surface Multi-Zone Vacuum Table	Welded Frame
Spindle	Motor & Drive	Control System	Auto Tool Changer
Air Cooled Spindle 16.1 hp (Options Available) 8,000 - 24,000 RPM	Beta 8 Drive	<b>FANUC</b> Oi-MF	20 HKS 63F 8 Linear Tools 12 Rotary Tool Changer
Machine Weight	Drill Bank	Tool Sensor	Lubrication System
4' x 8' 7,500 lbs	3200 RPM 2.3HP T21-T29	G54	Auto lubrication system for rack and pinions & ball screw
Bearings	Motion Supports		
X: HG25 Y: HG30 Z: HG25	Linear Guide: XY with rack & pinon drive. Ball Screw: on Z axis with hardened ball screw. Rack 1.25M Taiwan J&T / Rack has dust cover.		

## Machine Dimensions

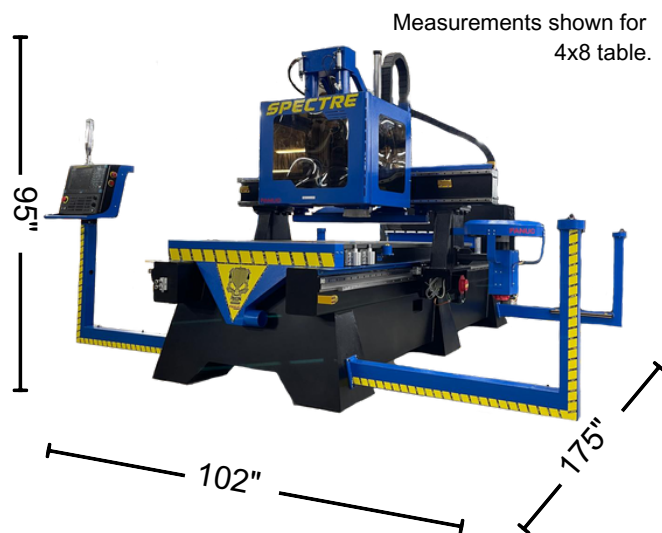

## Shipping Dimensions

These dimensions are the overall dimensions of the equipment shrink wrapped.

175"(L) x 102"(W) x 95"(H) / 199"(L) x 114"(W) x 95"(H)  
 Shipping cost vary on address and current carrier rates. Please contact for shipping quotes. Forklifts with 6ft forks are required.  
 Cabinet not included in dimensions.

## Vacuum Pumps

Phantom CNC Systems offers vacuum pumps in 2.2kw, 5.5kw, and 7.5kw to aid in supplying the correct vacuum pump needed for your CNC table. Sold separately.

## Dust Collection

Phantom CNC Systems offers several levels of dust collection to meet your needs. Our line-up of dust collectors include pleated filters. Sold separately.

## GET IN TOUCH

(252) 229-3896

info@phantomcn systems.com  
 www.phantomcn systems.com

276 Bailey Lane  
 Vanceboro, NC 28586

- 1 Bakelite Vacuum Table Surface
- 2 Spindle & Drill Bank Cover
- 3 Fanuc Oi-MF Controller
- 4 Ridid Tube Steel Gantry
- 5 Front Dust Trap
- 6 1.2kw Motors
- 7 Pnuematic Positioning Pins
- 8 Fully Welded Steel Frame

- Dust Boot 9
- Air Access Ports 10
- Safety Arms 11
- 9 Linear Drill Bank 12
- Linear Rail Stop 13
- 8 Position Tool Rack 14
- Indicator light 15
- 12 Position Rotary Tool Rack 16

the  
EVOLUTION  
OF CNC



INCLUDED

- 1 Welcome Package
- 1 Swag Bag
- 1 Spindle Cover
- 4 1/2" Collet
- 1 Dust Hose
- 1 Dust Boot
- 1 Spanner Wrench
- 1 Vacuum Hose
- 8 Tool Holders



FINANCING AVAILABLE

CONTACT US

276 Bailey Lane  
Vanceboro, NC 28586

(252) 229-3896  
www.phantomcncsystems.com